

# CONTROLS GUIDE FOR AIR-WATER HEAT PUMP SYSTEMS



# CONTENTS

---

INTRODUCTION	03
WHY ARE WE SEEING A RISE IN HEAT PUMP DEMAND?	03
HOW DOES AN OPTIMISED HEAT PUMP DIFFER FROM A CONDENSING BOILER OPERATED HEATING SYSTEM FROM A CONTROLS PERSPECTIVE?	04
HEAT PUMP SYSTEM OPERATIONAL CHARACTERISTICS	05
THE IMPORTANCE OF CONTROL COMMUNICATION	05
WHAT DOES APPROVED DOCUMENT L OF THE BUILDING REGULATION (2023 AMENDMENT) SAY?	06
HOW TO CONTROL A HEAT PUMP IN AN OPEN SINGLE ZONE CIRCUIT	07
HOW TO CONTROL A HEAT PUMP IN A ZONED SYSTEM (FLOOR AREA OR MULTI-ROOM)	09
APPENDIX 1: ALTERNATIVE OPTION FOR HYDRAULIC SEPARATION	14

## DISCLAIMER

Published in Great Britain in 2024 by BEAMA Ltd, Rotherwick House, 3 Thomas More Street, London E1W 1YZ

Copyright © BEAMA Ltd 2024

*All rights reserved. You may copy, store, distribute, transmit, reproduce or otherwise make available this publication (or any part of it) in any form, or by any means (electronic, digital, optical, mechanical, photocopying, recording or otherwise), without the prior written permission of the publisher provided that at all times the publisher is credited on every page or excerpt or graphic or image and the publishers copyright is acknowledged. The information, pictures, drawings, tables and text herein are provided for guidance only and no responsibility is accepted for any errors or omissions however arising nor is any guarantee or warranty given by or to be assumed from the information contained in this publication. The information has been provided by members of the BEAMA Underfloor trade association and is considered best practice at the time of publication however laws and building practices change and you are advised to seek independent advice before relying upon the information contained herein. Pictures and case studies or referenced material used herein are the copyright of the company named in the case study or credited.*

# INTRODUCTION

## Background

Building Regulations Approved Document L<sup>1</sup> was updated in 2021 to incorporate text from previous Domestic Building Services Guide. However, the requirements for heat pump controls could be clearer, particularly with regards to the requirements where TRVs are installed.

## Purpose

This guide is part of an evolution for system guidance, intended to assist domestic heat pump installers with considerations for controls strategies in various applications in a way that ensures compliance with Building Regulations Approved Document L. It provides a general approach which could be taken for new and existing hydronic heat pump only systems (note: bi-valent and hybrid systems are not included in scope). Additional considerations may be required for underfloor heating systems or non-radiator solutions. This document is not intended as a heat pump design guide. Generic exemplar schematics are provided for guidance purposes only. For each application, the system designer or installer must consider the requirements of all relevant Regulations, refer to heat pump manufacturers and system component manufactures instructions, and consider the specific building constraints and any preferences of the homeowner.

# WHY ARE WE SEEING A RISE IN HEAT PUMP DEMAND?

Heat pumps are growing in popularity in the UK with over 60,000 installations in 2023. They are fast becoming a mainstream heating technology in the drive to decarbonise UK homes and businesses. Significant market growth is expected in the period to 2035 and beyond as Government policies and regulations lay a path to switching our heating systems from fossil fuels such as natural gas and oil to electric heating. The electrification of heat will see a range of system options become available, and heat pumps will be the lead mass market technology.

A well designed and installed heat pump system is typically 3-4 times more efficient than fossil fuel boiler equivalents and can reduce carbon emissions by 70%, rising closer to 100% as the UK decarbonises electricity generation and supply.

Like all heating technologies, optimised heat pump system efficiency is critical to maximise performance and associated energy cost savings and comfort potential. This guide explores the optimal heat pump controls options available for installers to confidently advise homeowners to ensure compliance with building regulations and maximise system efficiency and comfort. To further support installers, the guide also includes 'homeowner advisory' sections which includes information to provide homeowners at the point of hand over.



<sup>1</sup> <https://www.gov.uk/government/publications/conservation-of-fuel-and-power-approved-document-l>

# HOW DOES AN OPTIMISED HEAT PUMP DIFFER FROM A CONDENSING BOILER OPERATED HEATING SYSTEM FROM A CONTROLS PERSPECTIVE?

Existing modern condensing boiler systems tend to deliver space heating hot water circulation at higher flow temperatures, typically up to 75°C, although they do require controls to ensure return temperatures are at a level to stimulate condensing mode.

The 2023 amendments to Approved Document L of the Building Regulations now require that where a wet emitter system is either (a) newly installed or (b) fully replaced in an existing building, including the heating appliance, emitters and associated pipework, then all parts of the system including pipework and emitters should be sized to allow the space heating to operate effectively and in a manner that meets the heating needs of the dwelling, at a maximum flow temperature of 55°C or lower.

To achieve the best efficiency, ideally heat pump systems are designed to lower distribution temperatures than existing condensing boilers i.e. below 55°C.

Heat pumps operate at an optimum performance efficiency if design consideration is given to the entire system including the heat pump itself, the primary and secondary distribution systems, and to the controls. Within this design, it will be necessary to minimise the difference between the outside temperature and the flow temperature at the design day, i.e. the outside temperature above which 99% of the heating hours occur. In addition, installers will need to pay careful attention to minimise the number of incidences of stop-start operation (or “compressor cycling”) in accordance with the manufacturer’s optimised heat pump performance characteristics to avoid negatively impacting the compressor lifetime. The chosen controls strategy or the introduction of a volume of water (e.g. a buffer tank or volumiser) strongly influences this to reduce cycling.

Careful consideration should also be given to how the heat pump controls the production of domestic hot water, which is commonly prioritised in a heat pump system.



# HEAT PUMP SYSTEM OPERATIONAL CHARACTERISTICS

There are several factors that determine heat pump system efficiency:

- Typically, in a low heat loss or new build property, heat pumps are not an intermittent heat source, operating most effectively for longer periods to maintain internal temperatures, taking into consideration the dwelling heat loss parameter and operating continuously by utilising room temperature set-back operation.
- Alongside time and temperature controls, the most critical control feature provides weather compensation functionality, either utilising internet information or a local external temperature sensor.
- Minimising the number of incidences of stop-start operation will preserve the compressor lifetime and performance efficiency of the heat pump.
- Where a heat pump requires a domestic hot water cylinder, ensure that it is designed to match the energy provided from the heat pump be mindful of the litres per minute required for optimum performance, coil output and manufacturers' recommended cylinder characteristics. Please refer to manufacturer's instructions for guidance.

# THE IMPORTANCE OF CONTROL COMMUNICATION

Installers must not assume that an existing control product within the building, such as a weather compensator, will be able to communicate with a new heat pump.

Check that the communication protocol of any existing control product is compatible with the chosen heat pump and that it will operate in accordance with the heat pump manufacturer's specification. Ensure that the controls between the heat pump and the system pumps and valves have a common communication protocol to avoid cycling.



## ADVISORY

*Typically, a reduction in maximum design flow temperature will result in 1-2% energy saving improvement for every 1°C.*

*The control set up for a heat pump system is different to traditional boilers. For example, boilers typically have mechanical or electronic time and temperature controls, and are designed for intermittent operation, e.g. 3 hours in the morning and 4 hours in the evening.*

*Heat pump systems are typically not operated on an intermittent basis and are usually designed to operate continuously for longer periods. They also typically have an option to switch between a daytime and set-back (lower) room / zone temperature to help optimise system performance and comfort levels within the home.*

*Where the heat pump control system combines time and room temperature controls from both the heat pump manufacturer and a third party, e.g. a third-party smart room thermostat, one of the systems needs to be the primary control. It must be made clear to the homeowner which one they are to interact with.*

# WHAT DOES APPROVED DOCUMENT L OF THE BUILDING REGULATIONS (2023 AMENDMENT) SAY?

## The Legal Requirement

### SCHEDULE 1 – APPROVED DOCUMENT L CONSERVATION OF FUEL AND POWER

L1. Reasonable provision shall be made for the conservation of fuel and power in buildings by:

- (a) limiting heat gains and losses –
  - (i) through thermal elements and other parts of the building fabric; and
  - (ii) from pipes, ducts and vessels used for space heating, space cooling and hot water services;
- (b) providing fixed building services which –
  - (i) are energy efficient to a reasonable standard;
  - (ii) have effective controls; and
  - (iii) are commissioned by testing and adjusting as necessary to ensure they use no more fuel and power than is reasonable in the circumstances.

## Guidance

### APPROVED DOCUMENT L OF THE BUILDING REGULATIONS OFFERS GUIDANCE AS A 'MEANS OF COMPLIANCE'

*“ The guidance then explains one or more ways to demonstrate how building work can be shown to comply with the legal requirements in common circumstances. The terms in green lettering in an approved document are key terms, listed and explained in the appendix to that approved document. Guidance in the approved documents addresses most, but not all, situations that building owners will face. Situations may arise that are not covered. You or your advisers will need to carefully consider whether following the guidance will mean that the requirements of the Building Regulations will be met. ”*

# HOW TO CONTROL A HEAT PUMP IN AN OPEN SINGLE ZONE CIRCUIT

This system type provides optimised performance for the heat pump, satisfying two key guidance requirements for Approved Document L of the Building Regulations (2023).

**5.18. Wet heating systems should ensure a minimum flow of water to avoid short-cycling.**

**6.39. The heat pump should have external controls that include both of the following.**

**(a) Weather compensation or internal temperature control.**

**(b) Timer or programmer for space heating.**

Therefore, a timer or programmer control which can determine the required period for heating and domestic hot water provision is required within Approved Document L of the Building Regulations.

Weather compensation control must be present with the control managing the temperature differential between outdoor and indoor target temperatures to maximise performance efficiency. Many heat pump controllers feature both weather compensation and internal temperature control, and care should be taken when commissioning and handing over the system to the homeowner.

Installers must ensure the heating circuit has sufficient open water volume to satisfy the minimum requirements of the heat pump with respect to achieving declared manufacturer performance, and where applicable, also to satisfy AHP manufacturers requirements for defrost mode. In addition, consideration must be given to ensure that the open circulating volume provides the optimum flow rate required by the manufacturer.

**Figure 1:** Automatic Bypass only – open loop

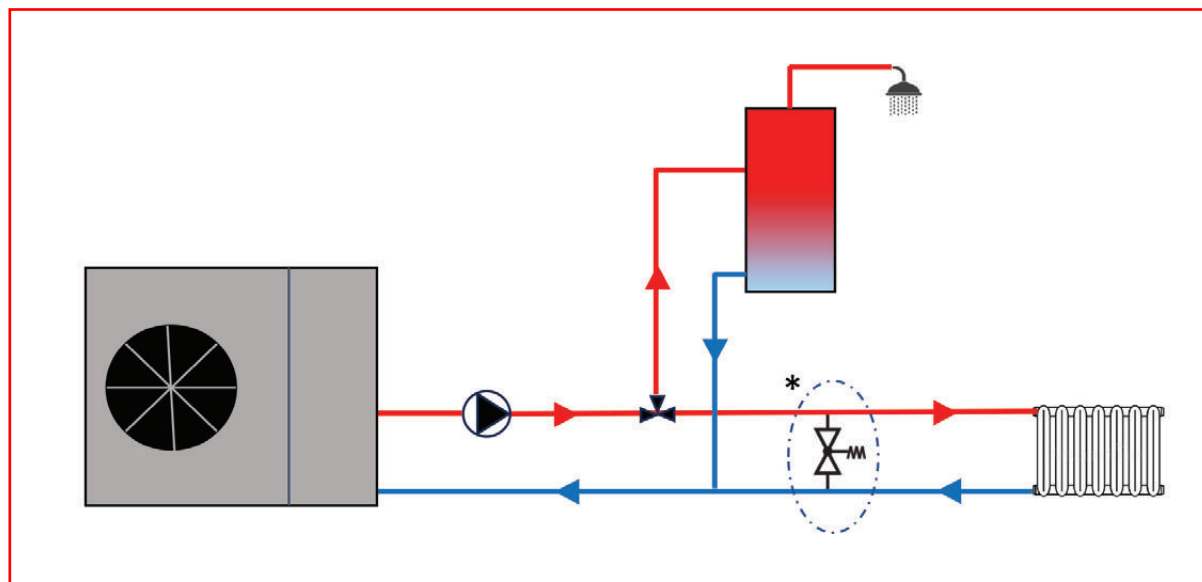

\* **Note:** optional automatic by-pass to future proof in case of future systems upgrades, e.g. TRVs (for zoned systems see section 2 for more information)

For an open, single zone heating circuit with no hydraulic break, any auxiliary pumps should be interlocked and controlled by the heat pump controller.

Where both radiators and underfloor heating circuits are installed in the same open loop arrangement intended to meet the minimum water volume, neither radiator TRVs nor UFH manifold actuators must be fitted. Also, the system will be designed to have the same flow temperature and delta T to both the radiators and the UFH system.

### ADVISORY

*In Figure 1, the system is designed to operate effectively without radiator TRVs or UFH manifold actuators and mixing valves.*

*This system is also designed to run at a lower temperature than traditional boilers.*

*Systems with an open zone with no TRVs may be subject to a homeowner request for additional zone controls. Give due consideration to the guidance relating to short cycling and ensure sufficient design parameters prevent this by introducing additional measures (see next section).*

**Figure 2:** Zone control (e.g. zone valves) – Auto Bypass + Volumiser

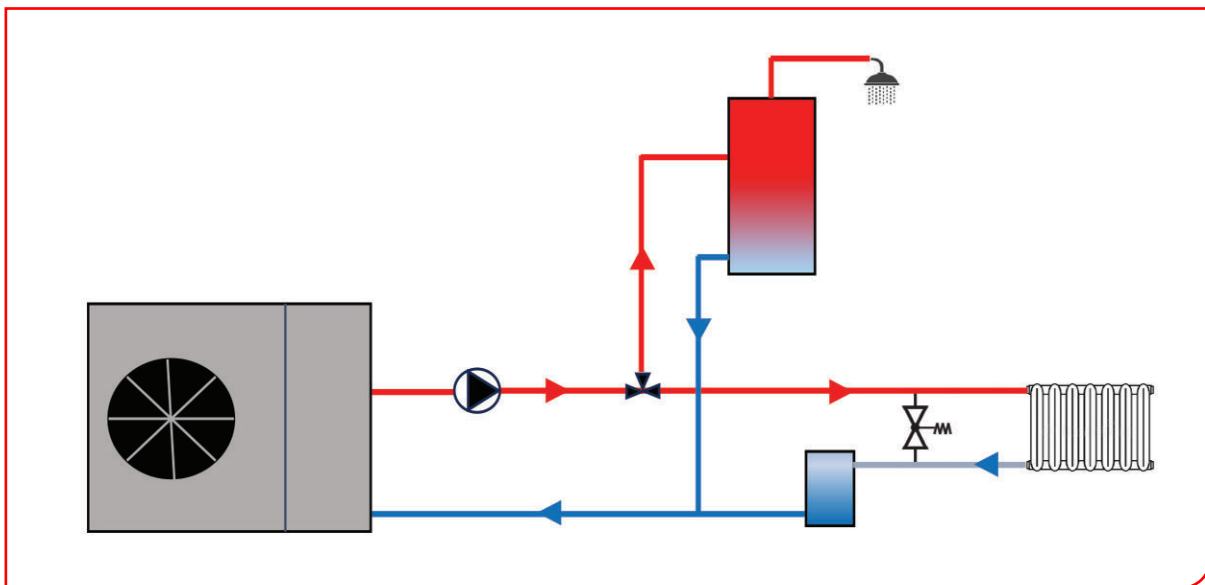

\* **Note:** zone valves including TRVs, are not shown for simplicity

# HOW TO CONTROL A HEAT PUMP IN A ZONED SYSTEM (FLOOR AREA OR MULTI-ROOM)

Specifiers or homeowners may specifically request multiple zones for their heat pump system. This section details minimum requirements which are intended to ensure minimum volume requirements are maintained to prevent short cycling of the heat pump and optimise system efficiency.

## Scenarios

- (i) same flow temperature but separate time and / or room temp control – could be upstairs/downstairs or different rooms.
- (ii) two different flow temperatures – UFH and radiators.

For scenario (ii), the weather compensator may have two separate heat curves for each zone.

Consider that each zone will require its own time and temperature control so that they operate separately and independently.

In these scenarios, to ensure minimum volume requirements are maintained, it is most likely a hydraulic separation (low loss header or buffer tank) will be required. This will mean that ancillary pumps are required downstream of the hydraulic separation as shown in Figures 3, 4 and 5.

Figure 3 is for where the primary circulating pump is controlled by and interlocked with the heat pump, or controlled independently and interlocked with the third-party room controls.

**Figure 3:** Zone control (e.g. zone valves) – Low Loss Header only for hydraulic separation

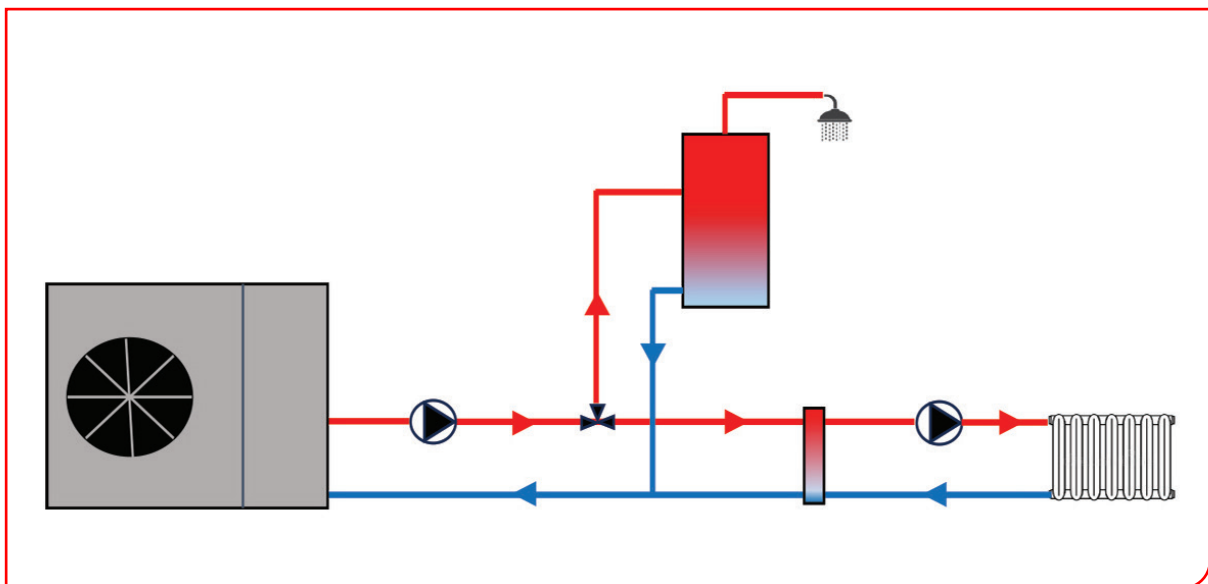

\* **Note:** zone valves including TRVs, are not shown for simplicity

Figure 4 is for where the primary circulating pump is controlled by and interlocked with the heat pump or controlled independently and interlocked with the third-party room controls.

**Figure 4:** Zone control (e.g. zone valves) – Low Loss Header (only for hydraulic separation) and additional volume (if required)

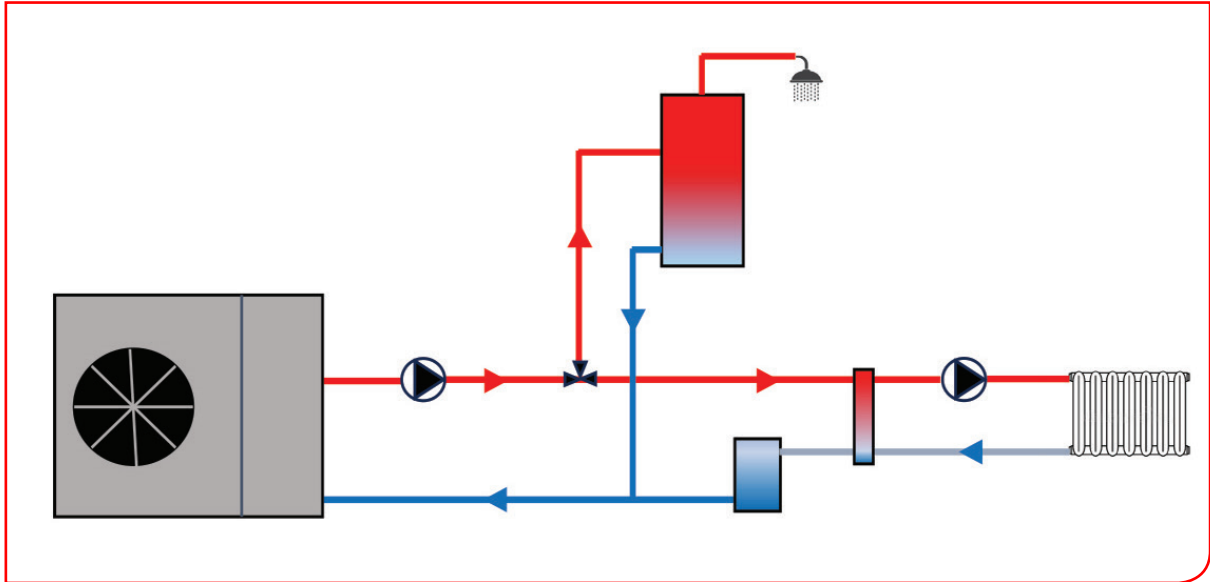

\* **Note:** zone valves including TRVs, are not shown for simplicity

In figure 5, the hydraulic separation and additional volume are provided for in one component, known as a buffer tank.

**Figure 5:** Zone control (e.g. zone valves) – Buffer Tank only (hydraulic separation and additional volume combined)

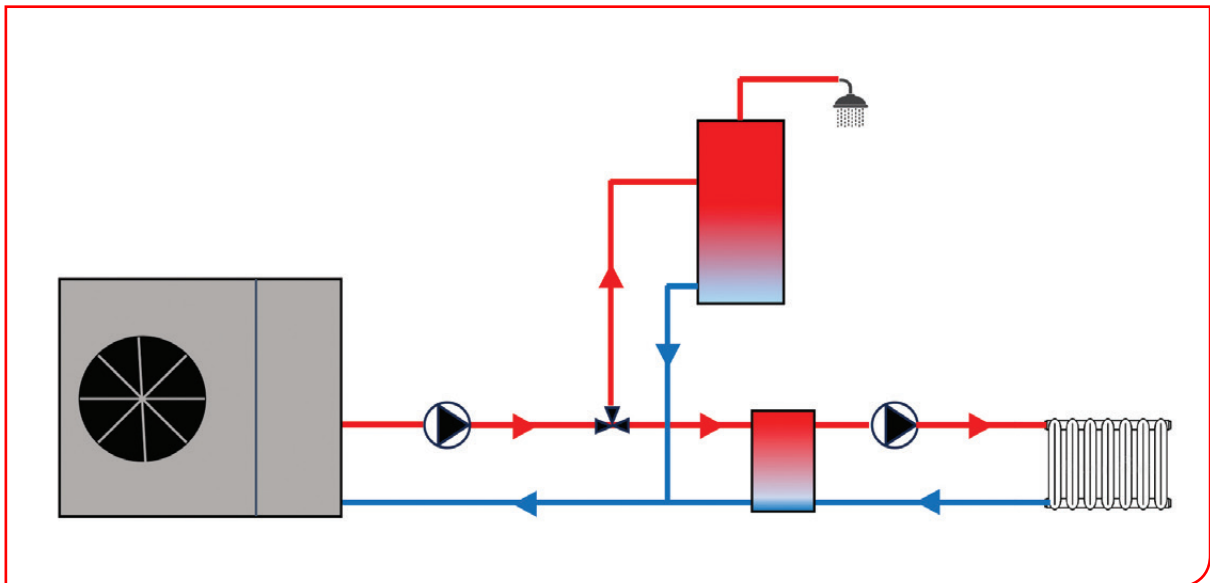

\* **Note:** zone valves including TRVs, are not shown for simplicity

Where fitted, the buffer tank temperature can be better controlled by the heat pump. This may either be by utilising a pipe sensor or buffer tank sensor.

Depending on the overall system design, it may be possible to avoid utilising a buffer tank as long as the minimum volume requirements can be assured once all TRVs and system valves are closed. In certain circumstances, a valve arrangement could provide an alternative to a buffer tank. Refer to specific manufacturer guidance. One example of an alternative arrangement is provided Appendix 1.

## Zoned System Controls

Guidance from the Regulations for thermostatic heating valves relating specifically to boilers is shown below. It recognises that “installing thermostatic room controls may not be technically feasible in some cases”. Consider this in context that the Regulations are intended to be outcome based with respect to optimising performance of the heating appliance and the system. Therefore, the controls specification should deliver optimum efficiency and comfort whilst not negatively impacting the lifespan of the heating appliance.



## Thermostatic room controls

**5.20.** For heating systems in new **dwelling**, or when a heat generator such as a boiler is replaced in an existing **dwelling**, each room should be provided with thermostatic room controls. These should be capable of being used to separately adapt the heating output in each room served by the **heating appliance**. Where justified in accordance with paragraph 5.21, heating may be controlled for each **heating zone** rather than individual rooms.

**NOTE:** There is no need to install thermostatic room controls in rooms/zones without heating in new or existing **dwelling**s.

**NOTE:** Installing thermostatic room controls may not be technically feasible in some cases. These may include the following.

- (a) **Dwellings** with very low heat demand (e.g. less than 10W/m<sup>2</sup>).
- (b) **Dwelling** with buffer zones for heat absorption or dissipation with high thermal mass.

**5.21.** It may be justified to control a **heating zone** rather than individual rooms in either of the following cases.

- (a) In single-storey open-plan **dwelling**s in which the living area is greater than 70% of the total floor area. In such cases, the **dwelling** should be considered as a single **heating zone**.
- (b) Where two adjacent rooms have a similar function and heating requirements (e.g. kitchen and utility room). In such cases, the adjacent rooms should be considered as a single **heating zone**.

**NOTE:** Exhaust air heat pump systems, which extract heat from the exhaust air of a dwelling, may not need to provide independent thermostatic control to individual rooms. Providing room/zone control on this type of system is unlikely to be economically and/or technically viable. However, other space heating systems also in use in the same dwelling should be controlled using thermostatic room controls as described above.

**NOTE: Commissioning** heating systems is covered in Section 8.

**5.22. The standards in paragraphs 5.20 and 5.21 may be satisfied by providing any of the following.**

- (a) Both of the following.
  - (i) A thermostat in a room that the heating circuit serves.
  - (ii) An individual thermostatic room control for each heat emitter, such as a thermostatic radiator valve, on all heat emitters outside the room that contains the thermostat. Thermostatic radiator valves should not be used in the same room as the thermostat.
- (a) An individual room/**heating zone** thermostat or fan coil thermostat for each room or **heating zone**.
- (b) An individual networked heat emitter control for each emitter.

Where TRVs (or eTRVS) are fitted, it is important to ensure that the minimum system volume is available at all times, especially where all TRVs and system valves are closed. It is therefore required to install a hydraulic separation that provides sufficient system volume on the primary side (heat pump side) for zone control when TRVs are in operational mode. Follow the minimum volume requirements for the specific heat pump manufacturer. In addition, no electro- or mechanical restrictions are to be fitted on the heat pump primary side.

**Examples of alternative arrangements that could be considered:**

- (i) an inline volumiser and by-pass valve arrangement, or
- (ii) a system bypass radiator in the reference room where the room thermostat is located which does not have a TRV fitted.

**ADVISORY**

*Homeowners need to be aware that they have two sets of time/temperature controls.*

*Installers must ensure any addition of zone controls complies with the requirement to prevent short cycling of the heat pump.*

## Domestic hot water controls with an air to water heat pump





A domestic hot water cylinder for an air to water heat pump will be sized to ensure it can satisfy the average demand profile (not a seasonal peak, e.g. Christmas), taking into account the number of bedrooms and domestic hot water points of use. Heat pump systems are usually commissioned as a domestic hot water priority system layout.

To meet the requirements of Building Regulations, domestic hot water cylinders must have a time control which is independent of the heating time control.

An electronic temperature control must be fitted to the cylinder, with the sensor sited as per the manufacturer's requirement.

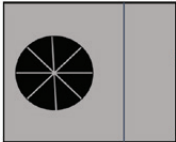
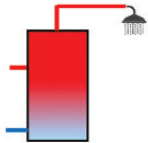
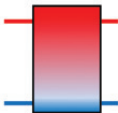
System controls must be able to raise the domestic hot water cylinder temperature for disinfection / pasteurisation purposes.

### Schematic Key

Description	Image
Air water heat pump	
Domestic hot water tank	
Buffer tank	
Volumiser	
Low loss header	
Bypass valve	
Circulating pump	

# APPENDIX 1: ALTERNATIVE OPTION FOR HYDRAULIC SEPARATION

An integrated thermal store (virtual buffer) which is designed to store primary hot water, and which can be used indirectly for space heating and direct for domestic hot water. The heated primary water is circulated to the space heating (e.g. radiators) through a plate heat exchanger with the option to transfer heat back out of the thermal store into the heating system. A schematic illustration of an integrated thermal store is shown in Figure 6.

**Figure 6:** Integrated Thermal Store (Virtual Buffer)

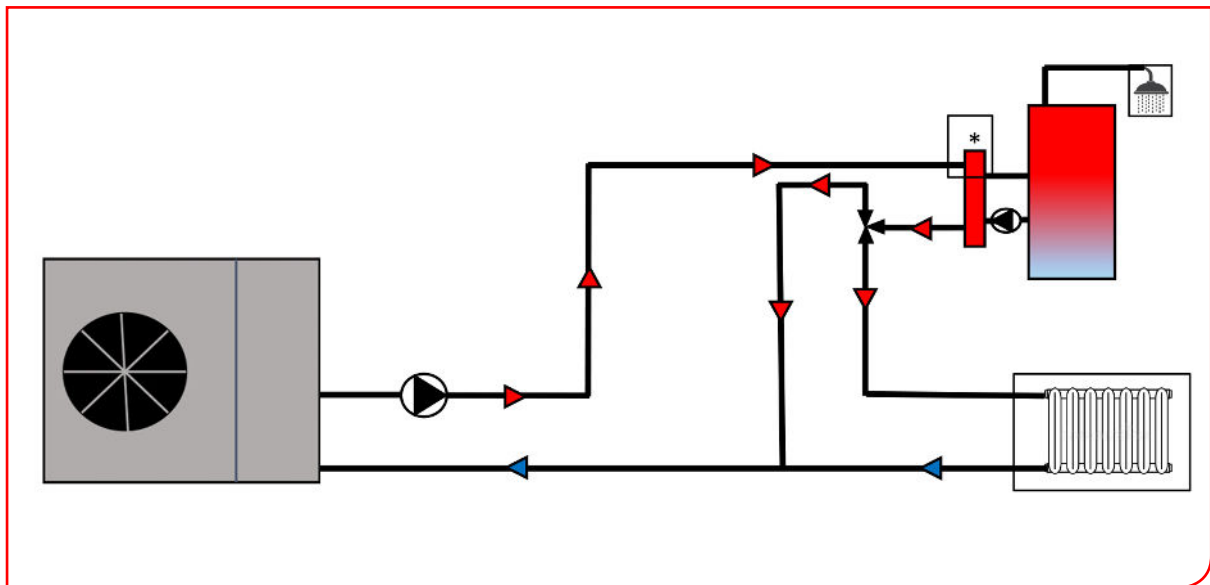

\* Plate heat exchanger



[www.beama.org.uk](http://www.beama.org.uk)



[www.heatpumps.org.uk](http://www.heatpumps.org.uk)